

MODEL EL-350H (SHOWN WITH 250 GALLON SINGLE WALL TANK)

- CABINET WEIGHT WITH BURNER AND BLOWER: ~ 415 LBS
- TANK WEIGHT EMPTY: ~ 425 LBS (600 LBS FOR 500 GALLON SW)
- FLUE DIAMETER: 8 INCH
- FREE AIR DELIVERY: ~2600 CFM
- HEATING AREA: UP TO 9000 SQ FT WITH 16' CEILINGS

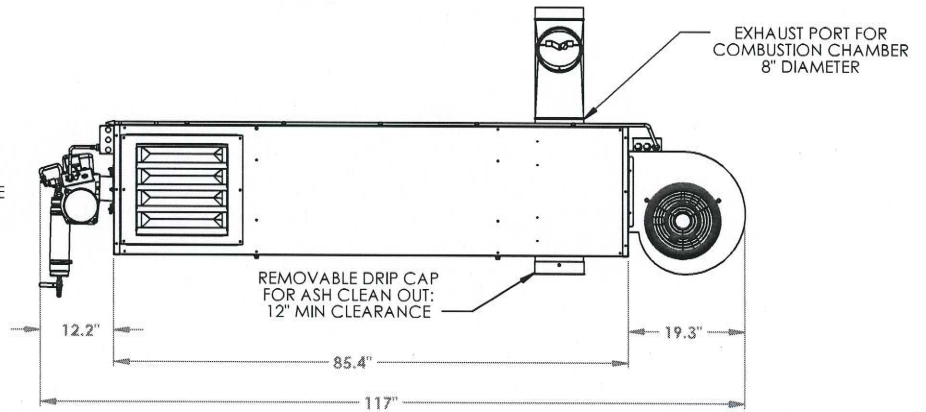
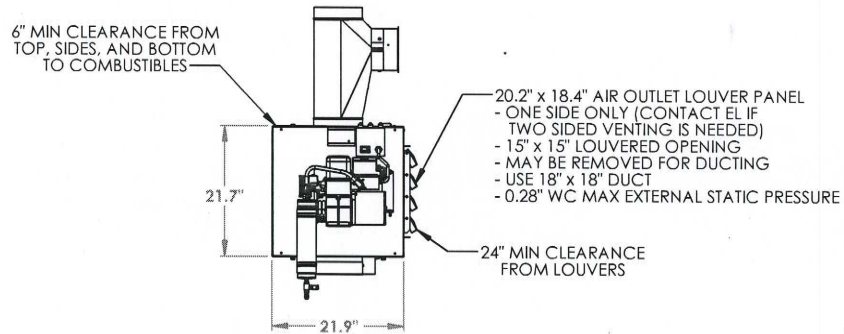
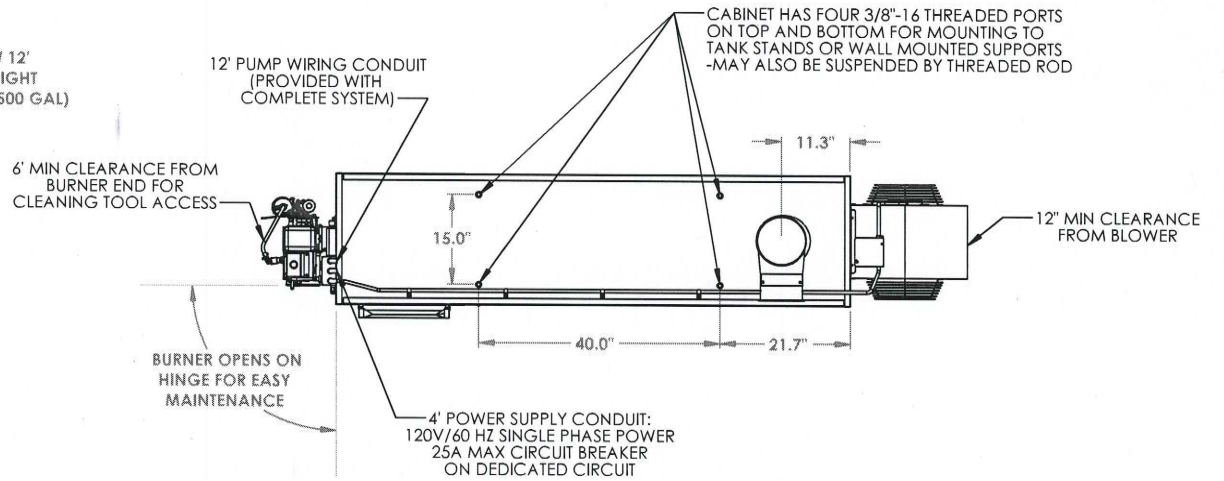

ITEM # 98030074