

MODEL EL-140H (SHOWN WITH 250 GALLON SW TANK)

- CABINET WEIGHT WITH BURNER AND BLOWER: APPR 295 LBS
- TANK WEIGHT EMPTY: APPR 425 LBS (600 LBS FOR 500 Gallon SW)
- FLUE DIAMETER: 8"
- FREE AIR DELIVERY: 1000 CFM
- HEATING AREA: APPR 3500 SQ FT WITH 16' CEILINGS

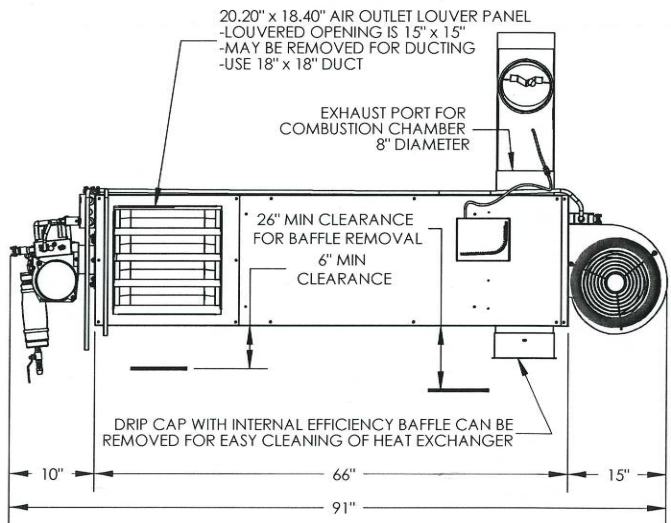
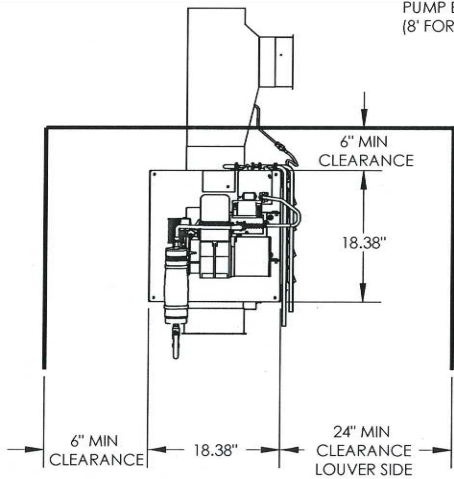
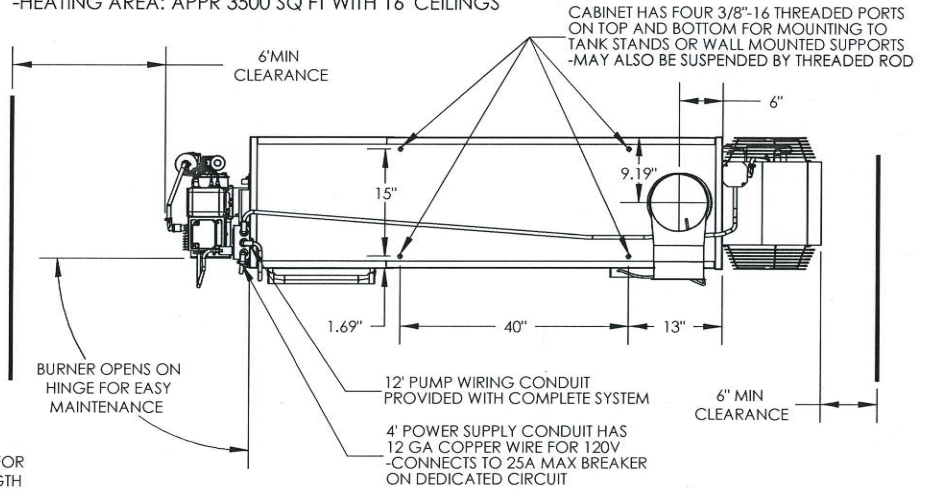

ITEM # 98030025